

**Recoules[®]
Quackenbush[®]**



**A1 Series
Positive Feed Drill**

January 2015



TOOLimpex
CZECH REPUBLIC s.r.o.

- Product Overview
- Applications
- Design Features
- Configurations & Options
- Related ATG Products



Productivity

- Up to 2.5hp/1.9kW* at the spindle to maximize cutting speed
- Vane and turbine governed motors to minimize speed drop when drilling
- Mitis™ option for chip fragmentation

Operating Cost

- 500 hours/100000 cycles PM** service interval
- Easy feed change (<15 mins)
- Modular design allows complete tool reconfiguration in hours

Ergonomic

- 35% weight reduction over previous models
- Uniquely configurable handles for best operating position

Quality

- Configurable error proofing
- Minimized speed drop for optimum hole quality and cutter life
- Optional counter for cutter change and service monitoring

A1 Series Positive Feed Drill

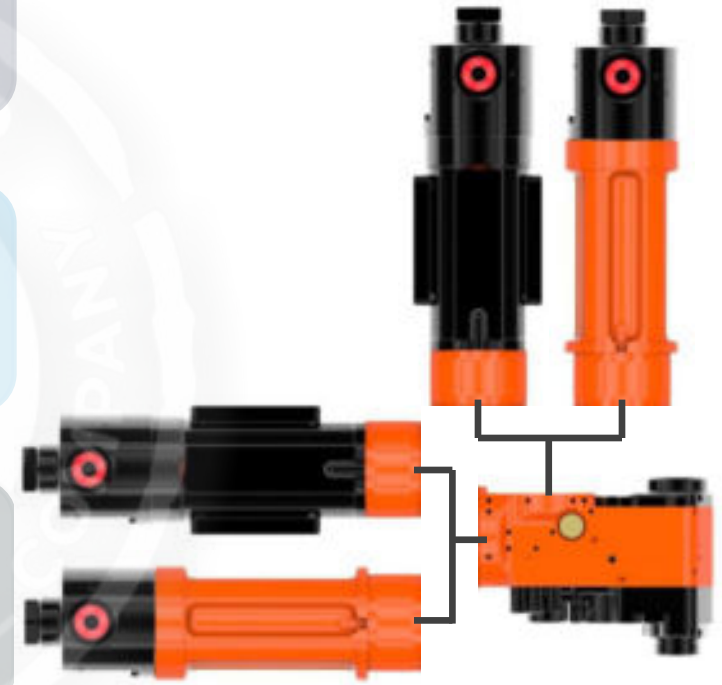

*Actual power dependent on tool speed and muffler configuration
**Mitis™ may require more frequent PM, refer to service manual

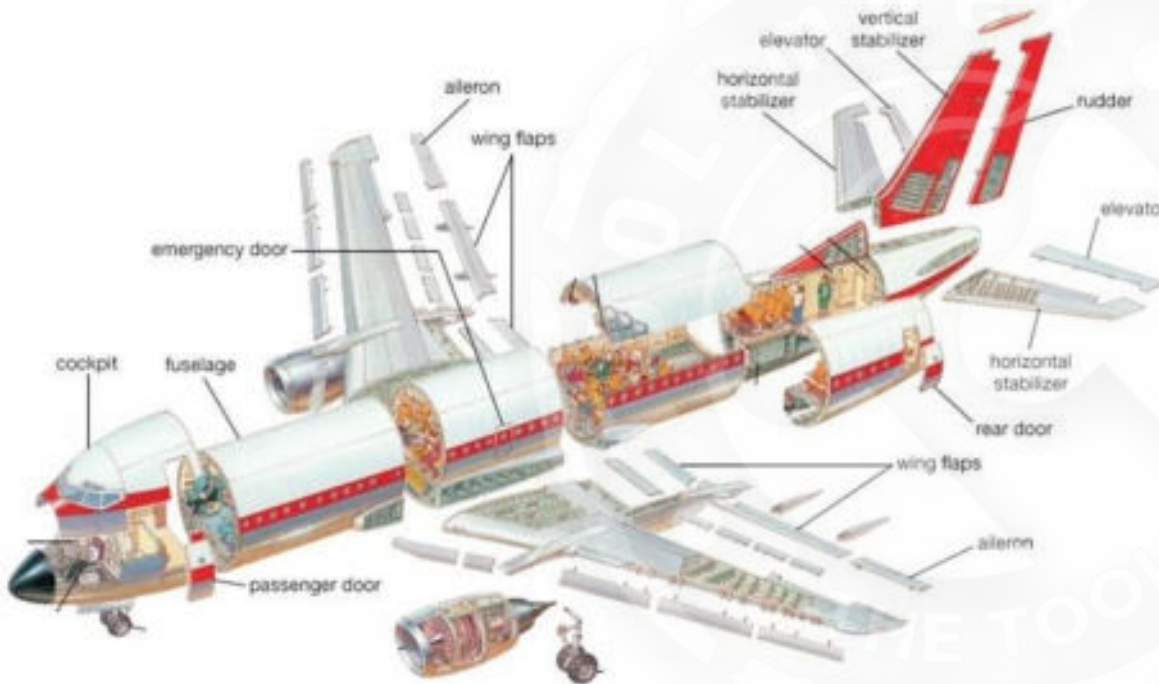

■ Holes

- Up to 3/4" /19mm in Titanium
- Up to 1"/25mm in Aluminium

■ Aero structure component drill, ream, countersinking

■ Aircraft final assembly

- Wing to body
- Fuselage
- Nose
- Doors
- Tail
- Stabilizer

Configurable Modular Design

Ergo Handle
for Right Angle



Twin Handle
for In Line



Pistol Handle
For In Line



Accessories
Electronic Counter



Coolant Lubricator



Gear Head
All new see later slides for features



Attachments

Base Tool
Configurable for Feed/Speed
Configurable for Right Angle/Inline
Configurable for Turbine/Vane Motor



Standard Nose
for 1/4 turn/twist lock
Vacuum Option



Concentric Collet
Vacuum Option



Template Foot
Vacuum Option



Auto Twist Lock (DASA)
Vacuum Option

- Easily customizable to suit YOUR application needs
- Ergonomic solution
- Optimize productivity
- Implement error proofing
- Use existing fixturing

All New Gear Head



- Easychange
- Integrated Mitis™
- Logiport

- Improved durability 500 hours/100000 cycle PM interval*
- Improved mechanical design to minimize jams
- Easy (15 minute) feed or Mitis™ change
- Logiport for configurable error proofing reducing defects
- Lower servicing cost



▪ Liftswitch

▪ Overtorque

- Extralife
- Overclutch

* Mitis™ may require more frequent PM, refer to service manual

Liftswitch – Mechanical initiation of retract

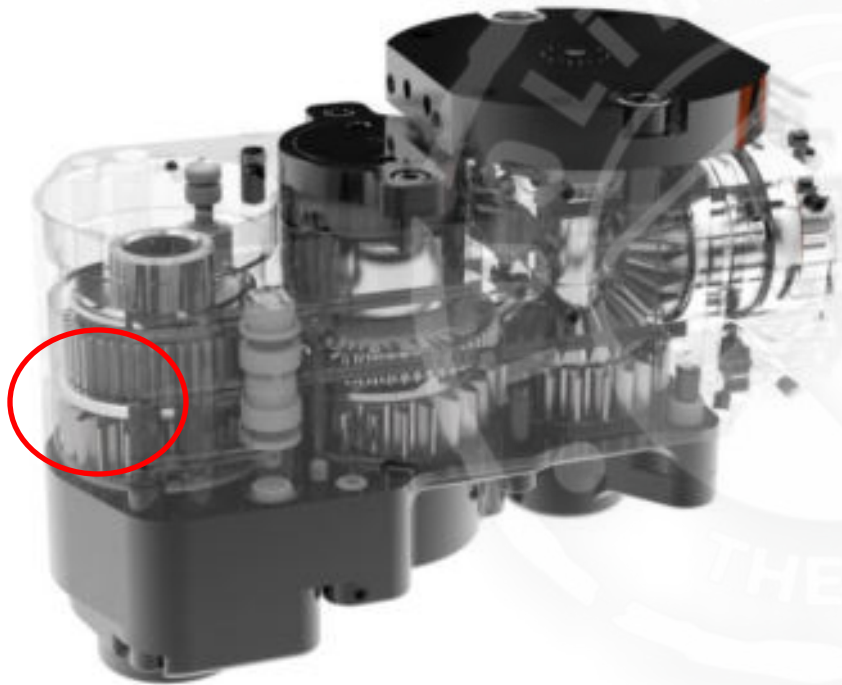

- Improved reliability
- Longer life
- Less defects
- Depth/dwell incorporated for accurate countersinking
+/- .001" .03mm



Overclutch - Overload for thrust through clutch drive



- Improved reliability
- Less defects

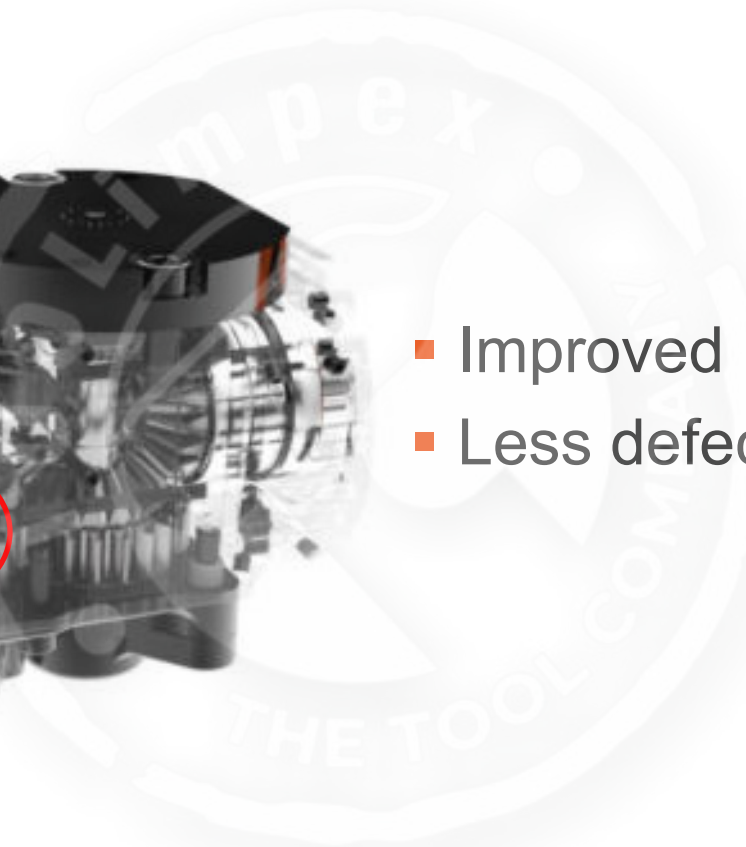

Extralife – No impact cone clutch for retract mechanism

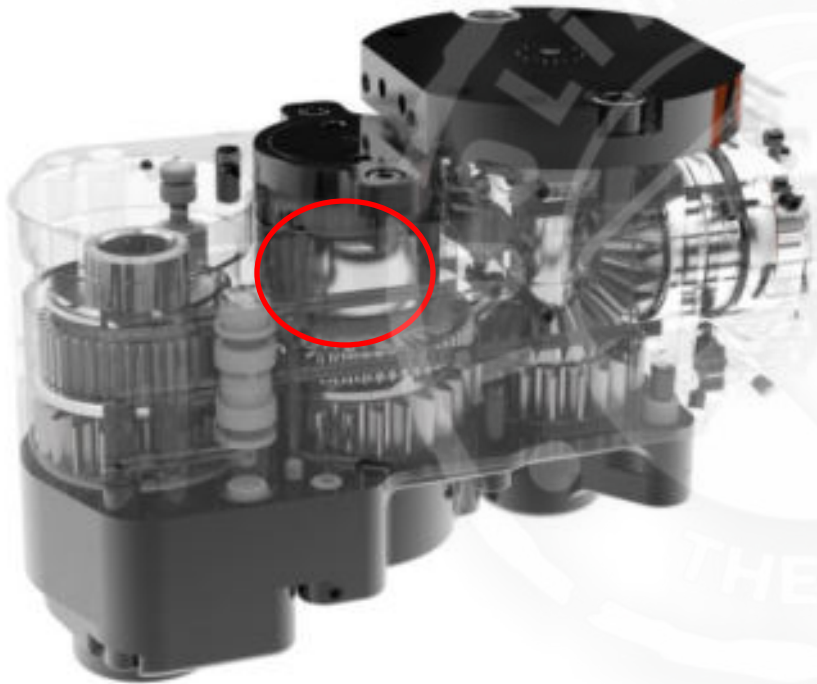

- Improved reliability
- No impact/less servicing
- Easy access for servicing/lower service cost

Overtorque – Overload for torque through shear pin train

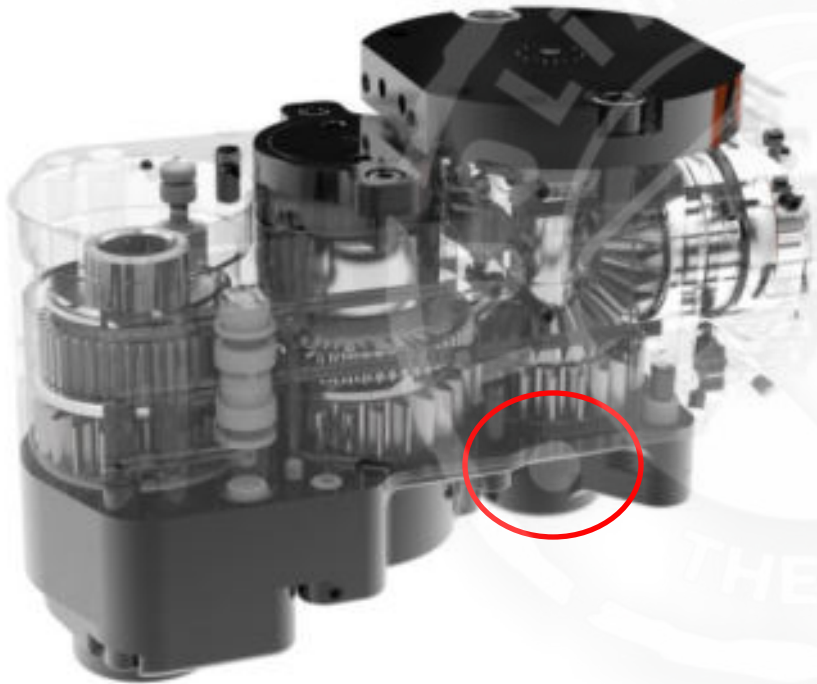

- Protects gears if torque is too high
- Longer gear head life
- Keeps tool weight down
- Can prevent drilling with damaged cutter/less hole defects

Logiport – Available connection for accessories/error proofing

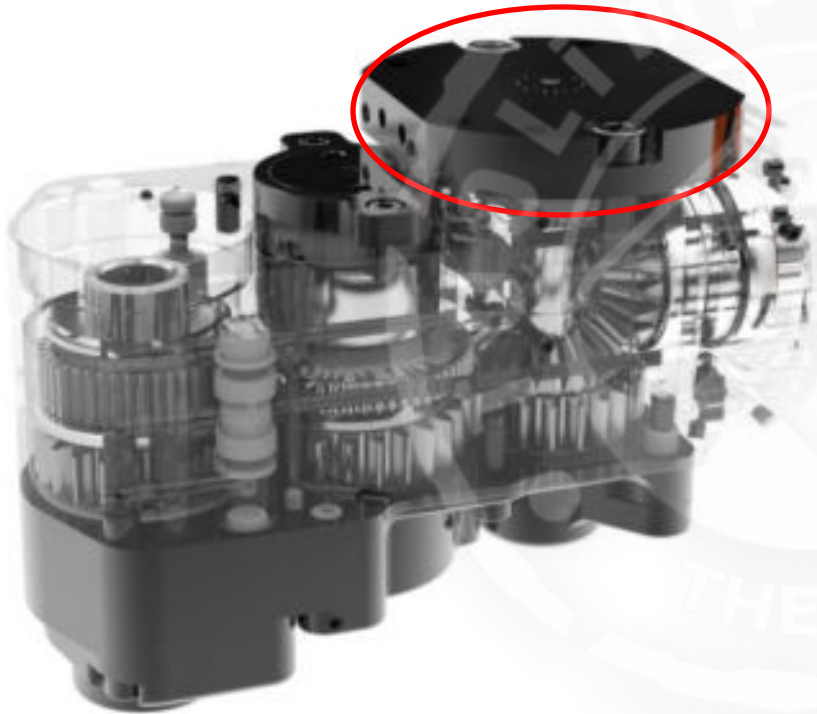

- Allows easy implementation of
 - Remote start
 - Start safety interlock
 - Air supply to accessories
 - Remote retract
 - Cycle complete
- Makes customization easier
- Get the configuration you want in less time
- Allows easy reconfiguration

Integrated Mitis™ – For chip fragmentation



- Mitis™ feature gives chip fragmentation while drilling
- Allows easier vacuuming of chips with less clean up time
- Reduces potential for torque/thrust overload as the hole gets deeper
- Allows less coolant with less clean up
- Can extend cutter life

Easy Change – For feed rate and mitis™

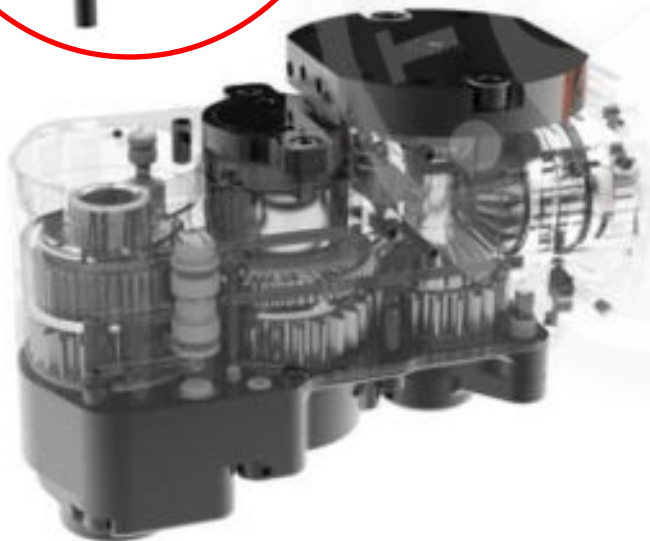

- Feed change in less than 15 minutes, allows easy reconfiguration and/or less time to repair.
- Mitis™ change in less than 15 minutes, allows easy reconfiguration and/or less time to repair.



Productivity

- Optimize drill time
- Minimize clean up time
- Reduce coolant use
- Optimize cutter usage
- Best ergonomics for maximum operator comfort

Operating Cost

- Less servicing
- Greater durability /longer overall life
- Can be easily and quickly reconfigured
- More holes per cutter

Ergonomics

- Reduce operator exposure to drilling forces
- Configure for best ergonomic operation
- Low tool weight reduces operator fatigue

Quality

- Controlled cutting with positive feed
- Configurable error proofing
- Electronic counter to monitor cutter cycles, maintenance interval

Configurations & Options

**Recoules
Quackenbush**



A14T



A14V



A16T



A16V

Tool thrust 500lbs at 90psi/6.3bar dynamic air supply

A Series Base Tool Options

Base Tool		Standard Option		Rated Speeds -0/+10%			Feeds		
Code	Base weight	Noise	Configuration	Code	Configuration	Turbine	Vane	ipr	mm/rev
A14V	7.3 3.3	<=85dBA	Right Angle Vane Motor	M	Internal Mitis	3200	3100 760	0.001	0.025
A14T	6.9 3.1	<=82dBA	Right Angle Turbine			2500	2800 670	0.002	0.05
A16V	7.1 3.2	<=85dBA	In Line Vane Motor			1700	2500 600	0.003	0.08
A16T	6.7 3.0	<=82dBA	In Line Turbine			950	2100 510	0.004	0.10
						750	1900 460	0.006	0.15
						600	1700 410	0.007	0.18
						400	1450 350	0.008	0.20
							950 320		
							850 250		

A Series Custom Tool Options and Accessories

Spindles	Specified based on stroke requirement and cutter thread interface
Spindle Guard	Specified based on spindle stroke and coolant method used
Nose Attachment	Based on application requirements
Concentric Collet	Based on application requirements
Template Foot	Based on application requirements
Handles	We have a range of standard handles developed or can customize one to suit your needs
Electronic Counter	For cutter, maintenance and overall tool life
Lubricator	Based on application requirements

Nose



Concentric Collet



Template Foot



Handles



Counter



Lubricator



Products

Advanced Drilling

- Positive Feed



- Self Colleting



Specialty Cutters

- Drilling
- Countersinking (Manual)
- Drill and Countersink
- Reamers
- Back Spot Face

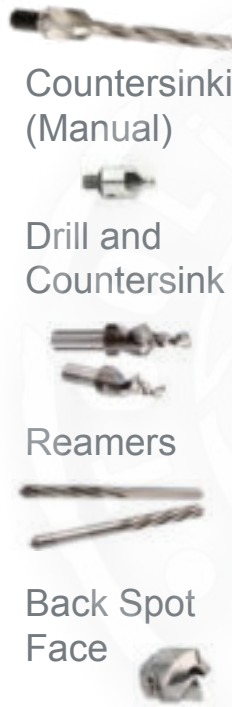

Tightening

- DC Electric Fastening
- Pneumatic Fastening
- Riveting
- Bits & Sockets

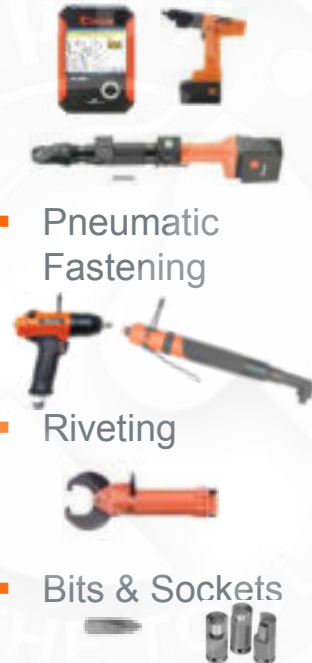

Material Removal

- Hand Drills & Microstop Cages
- Rivet Shavers
- Grinders
- Sanders

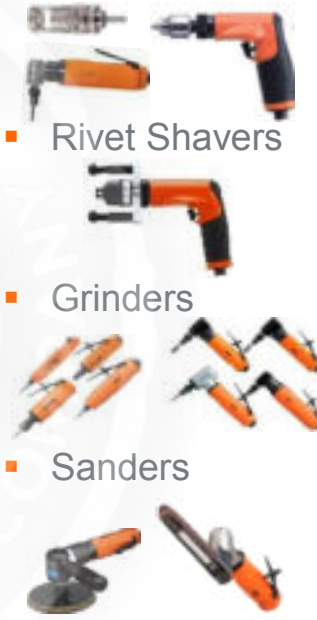

Universal Joints

- Universal Joints



**Custom Solution/
Service**



Brands

**Recoules
Quackenbush**



**Cleco
APEX**

**Recoules
DOTCO**

**Recoules
Quackenbush
Cleco
DOTCO**