



The next generation Pneumatic Riveter **R2A1**



Hrabinská 498/19, 737 01 Český Těšín, Česka republika

Mobil: +420 731 018 782

Mobil: +420 603 530 174



High endurance
Hydraulic oil filling required less often

Less than 0.2 mm stroke loss after 1,000,000 strokes

Hard ergonomic grip

Easy to hold and maneuver without slipping

Rounded edges

Lightweight 1.25kg

Designed for work-friendly use

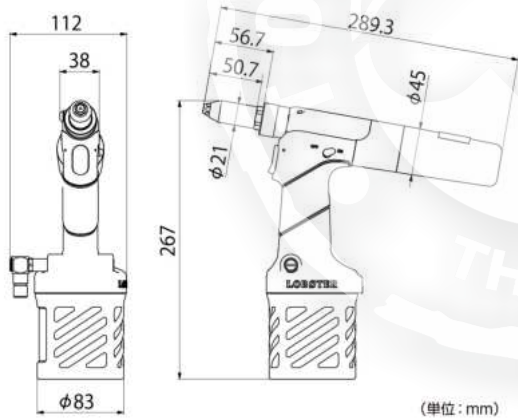

Improved functionality

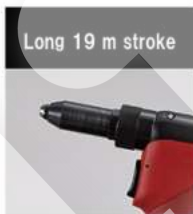

Long 19 mm stroke
Amplify long stroke despite the compact size of the riveter.



2-color molded ergonomic grip
The 2-color elastomer resin grip can be held in either hand without slipping or causing fatigue.



Interchangeable LR air supply ports
The R2A1 has air supply ports on both sides that users can interchangeably use to accommodate work shape and process.

Improved safety

Protective cover on cylinder cup
Equipped as a standard feature, this protective cover reduces the chances of damaging works.



Mandrel kick-out preventing shutter

As an improved safety feature, this shutter reduces the risk of mandrels being kicked out when the tank case is not mounted on the riveter and the vacuum is off.



TECHNICAL DATA

Model No	Model No.	R2A1
	Product weight (kg)	1.25kg ※1
	User range	Φ2.4、Φ3.2、Φ4.0、Φ4.8、(All types listed in Lobtex catalog) ※Optional support : high-strength rivets NSTB
	Stroke (mm)	19 mm
	Used air pressure MPa	0.5 ~ 0.6 MPa
	Output	9.0kN (Traction power at 0.6 MPa)
	Sound	Pressure level (Lpa) 75dB
	Air Consumption	Max. 82 L/min (Suction at 0.6 MPa)
	JAN Code	4963202004855
Package Item	nosepiece (Φ2.4、Φ3.2、Φ4.0、Φ4.8) , guide pipe (Φ2.4、Φ3.2) Guide Pipe Collar (Φ4.0、Φ4.8)	